

# A13-610 V8.0

## Technical Specification



### 1. Installation Dimensions

Case Dimensions	28.2mm*13mm*27mm
Weight	24g

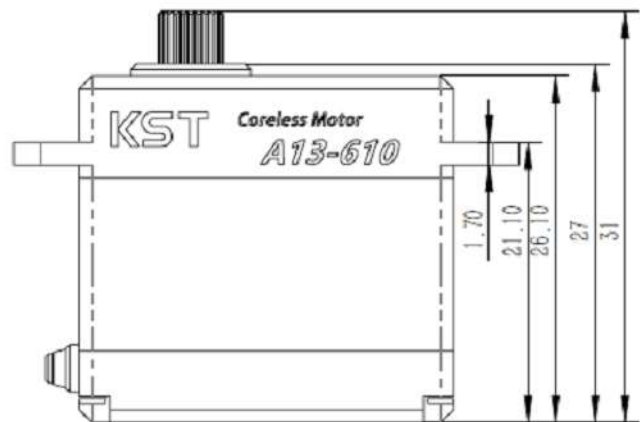
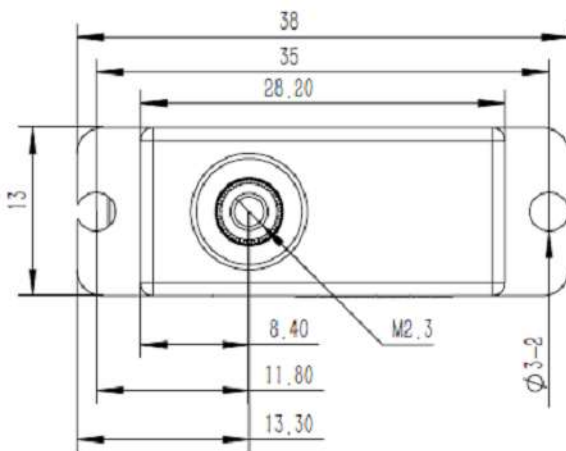

## 2. Operating Data

Operation Voltage(rated)	DC7.4V
Operation Voltage Range	DC4.8V-8.4V
Stalling Torque	5.5Kg.cm@4.8V
	6.5Kg.cm@6.0V
	8.0Kg.cm@7.4V
	9.0Kg.cm@8.4V
Speed	0.13sec/60°@4.8V
	0.12sec/60°@6.0V
	0.11sec/60°@7.4V
	0.10sec/60°@8.4V
Travel Angle	±50° when 1000-2000us
Operating Temperature Range	-10°C……+55°C

## 3. Performance

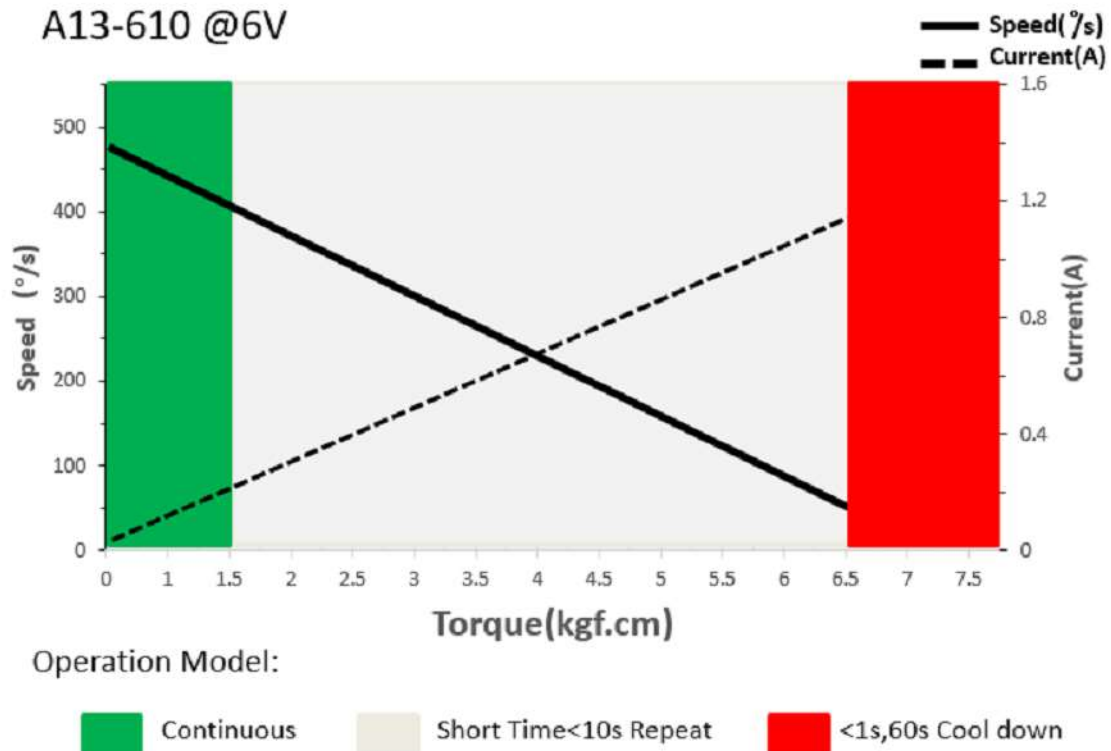

## 4. PWM Command Signal

Signal Voltage	TTL-Level: HIGH:min.3.3V,max.5.0V TTL-Level: Low:min.0.0V,max.1.5V
Pulse Lengths	800us - 2200us
Pulse Lengths for Position -50°/0°/+50°	1000us/1500us/2000us

## 5. Materials and protective features

Case Material	Aluminum Alloy
Motor Type	Coreless Motor
Gear Set Material	Hardened Steel
Position Sensor	Potentiometer

## 6. Output Shaft Spline (25T)

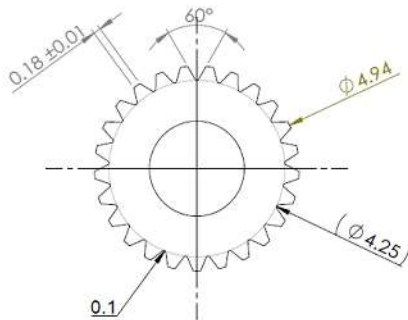

## 7. Electrical Connection

	Pin Assignment			
	1	Yellow	SIG	Command Signal
	2	Red	+V DC	Supply Voltage
	3	Brown	GND	Supply Ground, Signal Ground

## 8. Accessories (Options)

N/A