

SV12-12 Technical Specification

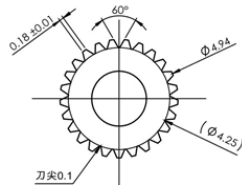

25T5mm Output Shaft Spline

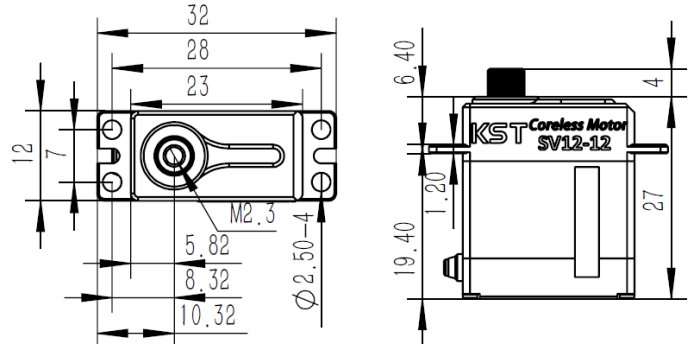

1. Operating Data

SV12-12	
Rated Voltage	DC12.0V
Voltage Range	DC8.40V-12.0V
Stalling Torque	6.5Kgf.cm@8.40V
	8.0Kgf.cm @12.0V
	9.0Kgf.cm @13.0V
Speed	0.15sec/60°@8.40V
	0.11sec/60°@12.0V
	0.10sec/60°@13.0V
Working Frequency	1520us/333Hz
Default Travel Angle	±70° = 140° Total
Temperature Range	-10°C.....+65°C
Soft Start	Programmable
Programmable	Yes
Case Material	Aluminum Alloy
Motor Type	Coreless DC Motor
Gear Set Material	Hardened Steel
Position Sensor	Potentiometer
Case Dimensions	23mm*12mm*27mm±0.2mm
Weight	20g±10%

2. Performance

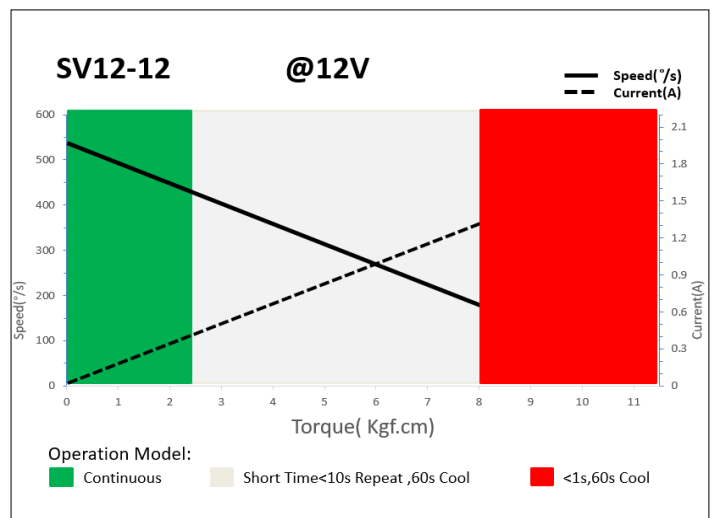

3. Command signal

PWM Command Interface

Signal Voltage	HIGH: min.3.3V, max.5.0V Low: min.0.0V, max.1.5V
Pulse Lengths	800us-2200us
Pulse Lengths for Position -50° 0°+50°	1000us/1500us/2000us

4. Electrical Connection

 3 2 1	Pin Assignment			
	1	Orange	Signal	PWM Command
	2	Red	DC+	Supply Voltage
	3	Brown	DC-	Supply Ground