

## HA20-9015 Technical Specification

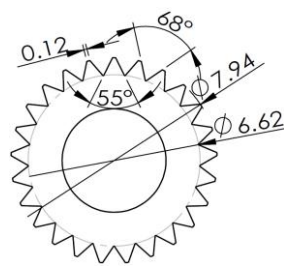

8mm25T Output Shaft Spline

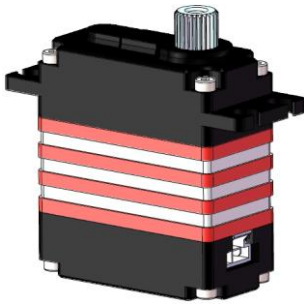
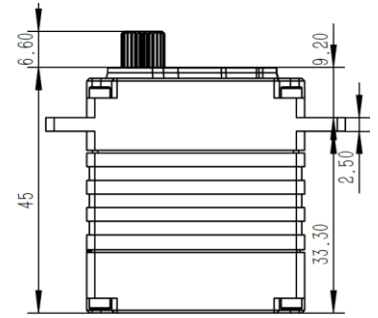
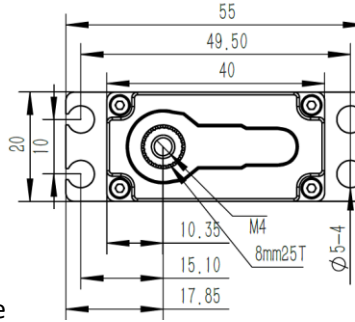

### 1. Operating Data

Rated Voltage	DC7.4V
Voltage Range	DC6.0V-8.4V
Torque	70Kgf.cm@6.0V
	80Kgf.cm@7.4V
	90Kgf.cm@8.4V
Speed	0.17sec/60°@6.0V
	0.16sec/60°@7.4V
	0.15sec/60°@8.4V
Stalling Current	9.80A@6.0V
	11.8A@7.4V
	13.5A@8.4V
Working Frequency	1520us/333Hz
Default Travel Angle	±100° =200° Total
Temperature Range	-10°C.....+65°C
Programmable	Yes
Case Material	Aluminum Alloy
Motor Type	Brushless DC Motor
Gear Set Material	Hardened Steel
Position Sensor	Contactless
Ball Bearing	2BB
Case Dimensions	40*20*45mm±0.2mm
Weight	90g±10%

### 2. Performance

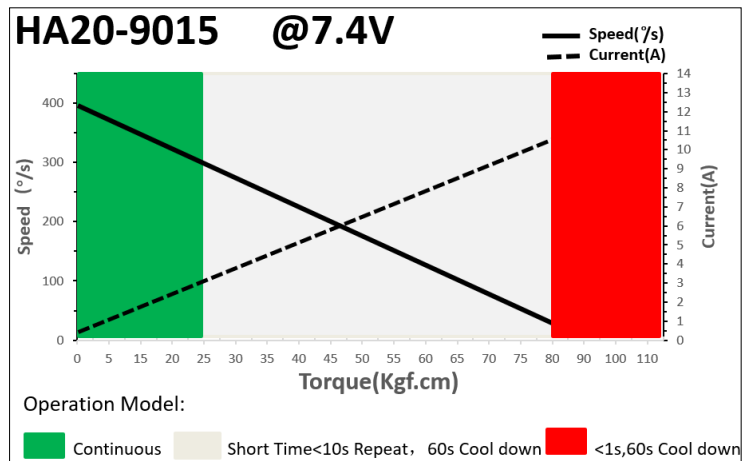

### 3. PWM Command Interface

Signal Voltage	HIGH: min.3.3V, max.5.0V Low: min.0.0V, max.1.5V
Pulse Lengths	500us-2500us
Pulse Lengths for Position -100°/0°/+100°	500us/1500us/2500us

### 4. Electrical Connection

Manufacturer: CJTconn Type: A2509WRA-F-3P-G15

Mating: A2509HFA-3P

Pin Assignment	Pin Assignment		
	1	DC-	Supply Ground
	2	DC+	Supply Voltage
	3	Signal	PWM Command

### 5. Horn: 0825.38

