

SV12T-12 Technical Specification

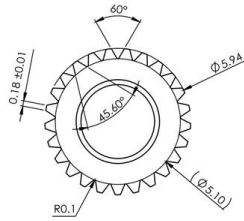

25T-6mm Output Shaft Spline

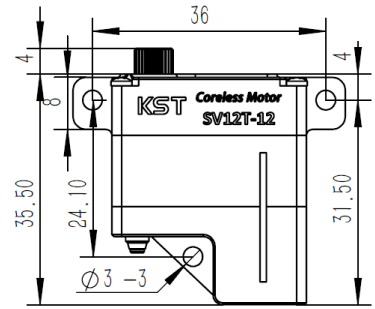
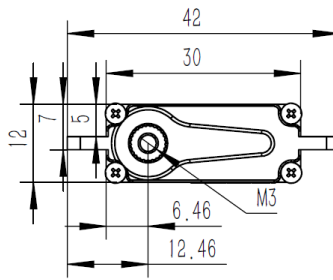

1. Operating Data

SV12T-12	
Rated Voltage	DC12.0V
Voltage Range	DC8.4V-12.0V
Stalling Torque	16.0Kgf.cm@8.40V
	20.0Kgf.cm@12.0V
	22.0Kgf.cm@13.0V
Speed	0.16sec/60°@8.40V
	0.12sec/60°@12.0V
	0.11sec/60°@13.0V
Working Frequency	1520us/333Hz
Default Travel Angle	±60° = 120° Total
Temperature Range	-10°C+65°C
Soft Start	Yes
Programmable	Yes
Case Material	Aluminum Alloy
Motor Type	Coreless DC Motor
Gear Set Material	Hardened Steel
Position Sensor	Potentiometer
Ball Bearing	2BB
Case Dimensions	30mm*12mm*35.5mm±0.2mm
Weight	32g±10%

2. Performance

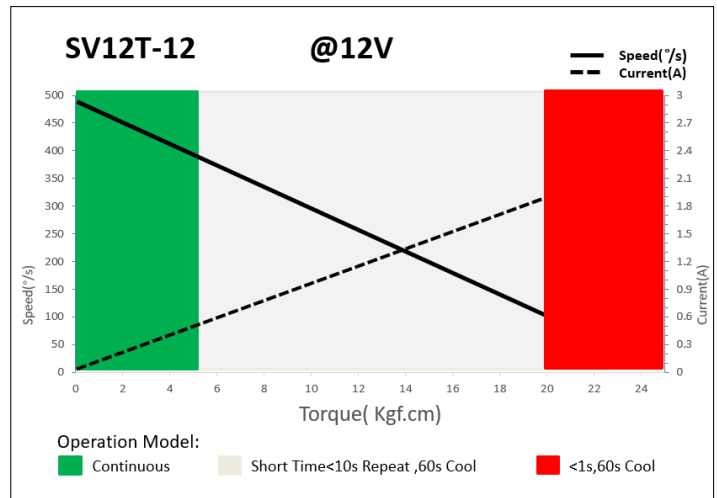

3. Command signal

PWM Command Interface

Signal Voltage	HIGH: min.3.3V, max.5.0V Low: min.0.0V, max.1.5V
Pulse Lengths	900us-2100us
Pulse Lengths for Position -50°/ 0°/+50°	1000us/1500us/2000us

4. Electrical Connection

	Pin Assignment			
	1	Orange	Signal	PWM Command
	2	Red	DC+	Supply Voltage
	3	Brown	DC-	Supply Ground