

X30-28-180-* V8.0 HLS Technical Specification

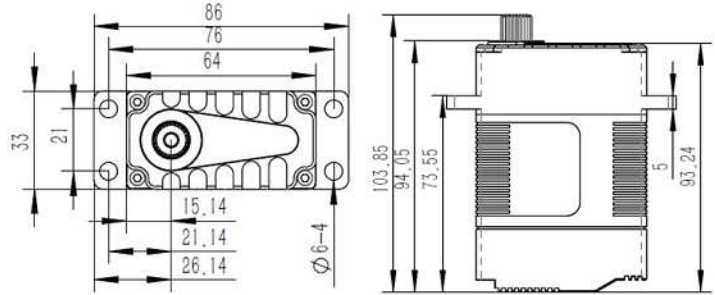
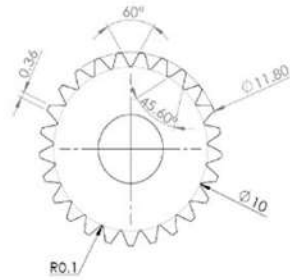
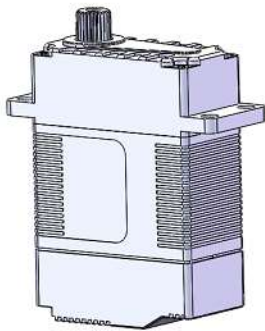

Output Shaft Spline (25T&12mm)

1. Servo Data

	X30-28-180-*
Rated Voltage	DC28V
Voltage Range	DC24V-32V
Stalling Torque	13.5N.m@24V
	18N.m@28V
Speed	0.24sec/60°@24V
	0.18sec/60°@28V
Working Frequency	1520us/333Hz
Default Travel	±50°=100° Total
Temperature	-20°C.....+65°C
Case Material	Aluminum Alloy
Motor Type	Brushless DC Motor
Gear Set Material	Hardened Steel
Position Sensor	Potentiometer
Case Dimensions	64mm*33mm*94mm±0.2mm
Weight	435g±10%
Ball Bearing	7 BB

2. Performance

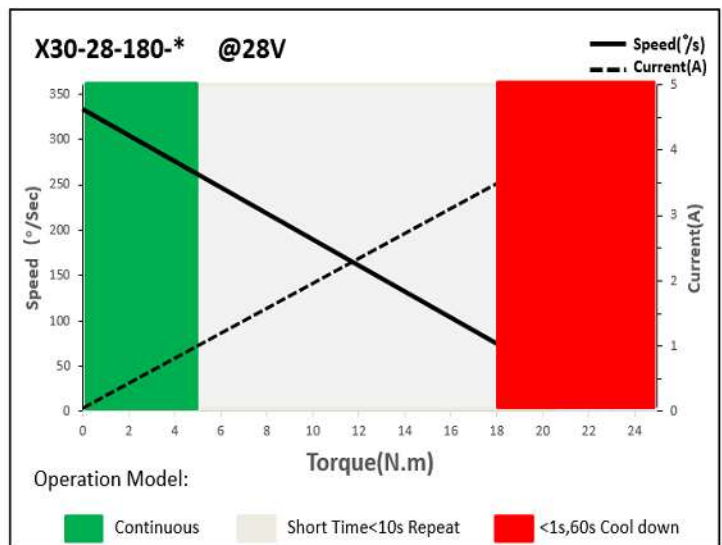

3. Command signal

3.1. PWM Command Interface

Signal Voltage	HIGH: min.3.3V, max.5.0V Low: min.0.0V, max.1.5V
Pulse Lengths	900us-2100us
Pulse Lengths for Position	1000us/1500us/2000us -50°/ 0°/+50°

3.2. RS485 Command Interface

Baud-Rate	115200 ±1.5% bits/s
Protocol	10 Byte (incl. 1 byte Check Sum)
(Documentation	8
Number of Data	1
Number of Stop	None

Bits

Command / Response Frame			
Byte #	Description	Byte #	Description
1	Frame Head(0xFE)	6	Data
2	Version(0xCA)	7	Data
3	Address	8	Data
4	Command code	9	Check Sum
5	Data	10	(0A) Frame End

3.3 CAN Bus Command Interface

Baud-Rate	500Kbps	Communication	3.1: CAN Open standard frame 3.2: CAN Extended frame
Node number	0 x25 (range 1 ~ 127, 0 is radio)		

3.4. Feedback Signal

3.4.1 Position Feedback Signal (PWM Versions)

The Position Feedback signal is an output signal with a square wave which is directly related to the output shaft's angular position. Reference is Supply Ground.

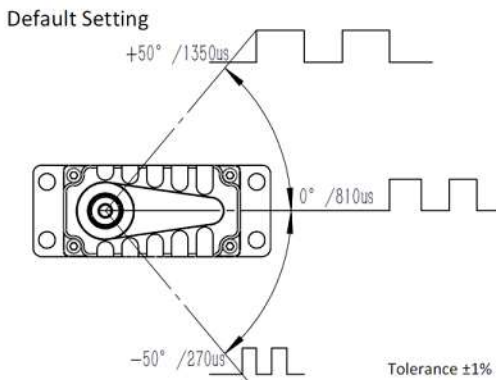

Position Feedback

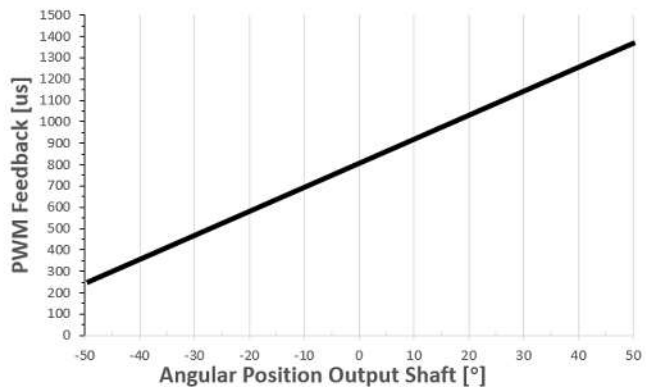

3.4.2 Feedback Value (Bus Version)

Integrated in the Bus protocol a Feedback Value, including the Angle position, Temperature, current value. Value read by sending request command. Provide the details of the bus in the document.

4. Electrical Connection Options

Industrial Standard J30J-9ZKP electrical Connector

	Assignment PWM		Assignment RS485		Assignment CAN	
	1	DC + Supply Voltage	1	DC + Supply Voltage	1	DC + Supply Voltage
	2		2		2	
	3		3		3	
	4	DC- Supply Ground	4	DC- Supply Ground	4	DC- Supply Ground
	5		5		5	
	6		6		6	
	7	PWM Signal	7	Do not connect	7	Do not connect
	8	Feedback Signal	8	RS485A	8	CAN_H
9	Signal Ground	9	RS485B	9	CAN_L	

*: 1-PWM, 2- RS485, 3.1- CANBUS Standard Frame 3.2- CANBUS Extended Frame