

### X30-12-200-\* V8.0 HLS Technical Specification

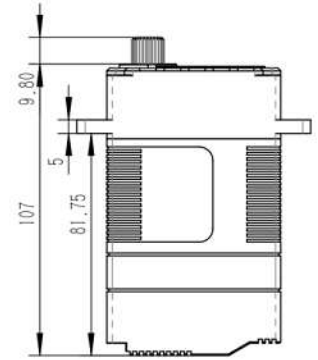
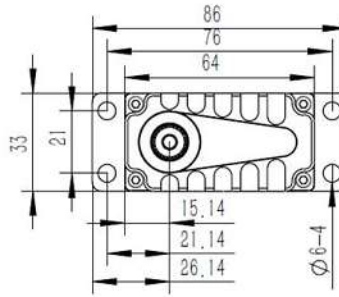
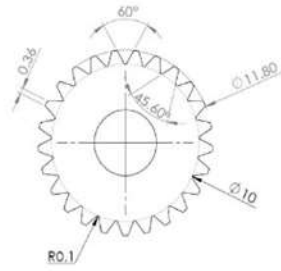
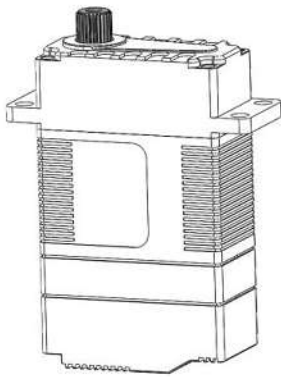

Output Shaft Spline (25T&12mm)

## 1. Servo Data

X30-12-200-*	
Rated Voltage	DC12V
Voltage Range	DC8.4V-12V
Stalling Torque	20N.m@12V
Rated Torque	6N.m@12V
Stalling Current	8.80A
Rated Current	2.40A
No-load Speed	0.27sec/60°@12V
Rated Speed	0.37sec/60°@12V
Working Frequency	1520us/333Hz
Default Travel Angle	±50°=100° Total
Temperature Range	-20°C.....+65°C
Case Material	Aluminum Alloy
Motor Type	Brushless DC Motor
Gear Set Material	Hardened Steel
Position Sensor	Potentiometer
Case Dimensions	64mm*33mm*107mm±0.2mm
Weight	550g±10%
Ball Bearing	7 BB

## 2. Performance

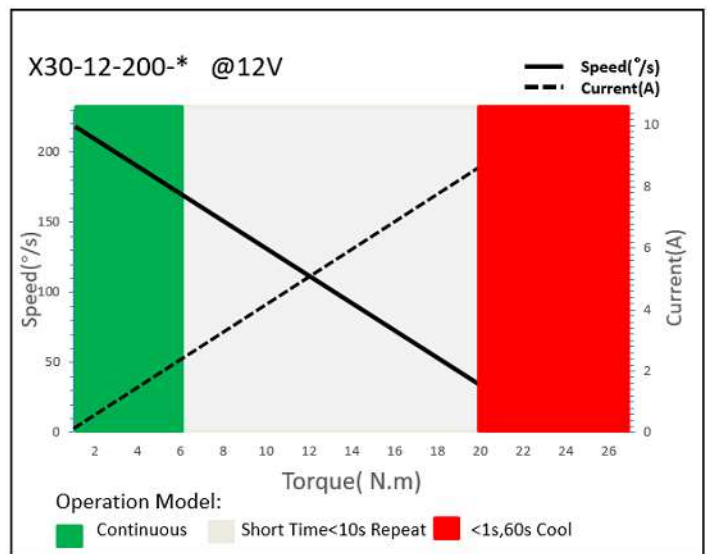

## 3. Command signal

### 3.1. PWM Command Interface

Signal Voltage	HIGH: min.3.3V, max.5.0V Low: min.0.0V, max.1.5V
Pulse Lengths	900us-2100us
Pulse Lengths for Position	1000us/1500us/2000us -50°/0°/+50°

### 3.2. RS485 Command Interface

Baud-Rate	115200 ±1.5% bits/s
Protocol	10 Byte (incl. 1 byte Check Sum)
(Documentation)	8
Number of Data	1
Number of Stop	None

Bits

Command / Response Frame			
Byte #	Description	Byte #	Description
1	Frame Head(0xFE)	6	Data
2	Version(0xCA)	7	Data
3	Address	8	Data
4	Command code	9	Check Sum
5	Data	10	(0A) Frame End

### 3.3 CAN Bus Command Interface

Baud-Rate	500Kbps	Communication	3.1: CAN Open standard frame
Node number	0 x25 (range 1 ~ 127, 0 is radio)		3.2: CAN Extended frame

### 3.4. Feedback Signal

#### 3.4.1 Position Feedback Signal (PWM Versions)

The Position Feedback signal is an output signal with a square wave which is directly related to the output shaft's angular position. Reference is Supply Ground.

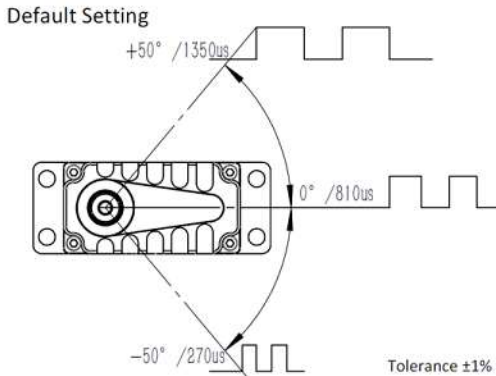

Position Feedback

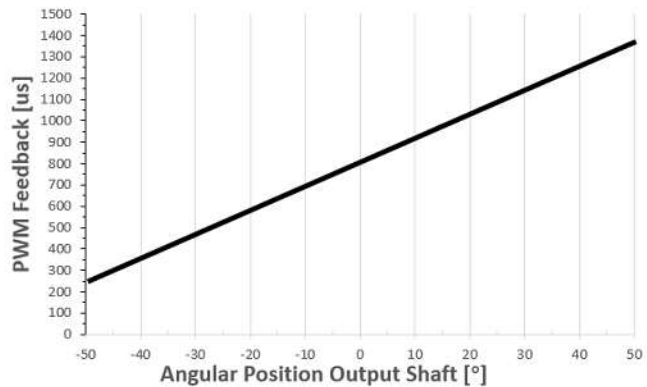

#### 3.4.2 Feedback Value (Bus Version)

Integrated in the Bus protocol a Feedback Value, including the Angle position, Temperature, current value. Value read by sending request command. Provide the details of the bus in the document.

## 4. Electrical Connection Options

Industrial Standard J30J-9ZKP electrical Connector

Assignment PWM	Assignment RS485		Assignment CAN		
	1	2	1	2	
1	DC + Supply Voltage	1	DC- Supply Ground	1	DC + Supply Voltage
2		2		2	
3		3		3	
4	DC- Supply Ground	4	Do not connect	4	DC- Supply Ground
5		5		5	
6		6		6	
7	PWM Signal	7	RS485A	7	Do not connect
8	Feedback Signal	8	RS485B	8	CAN_H
9	Signal Ground	9		9	CAN_L

\*: 1-PWM, 2- RS485, 3.1- CANBUS Standard Frame 3.2- CANBUS Extended Frame