

HS08A&B V6.0 Technical Specification

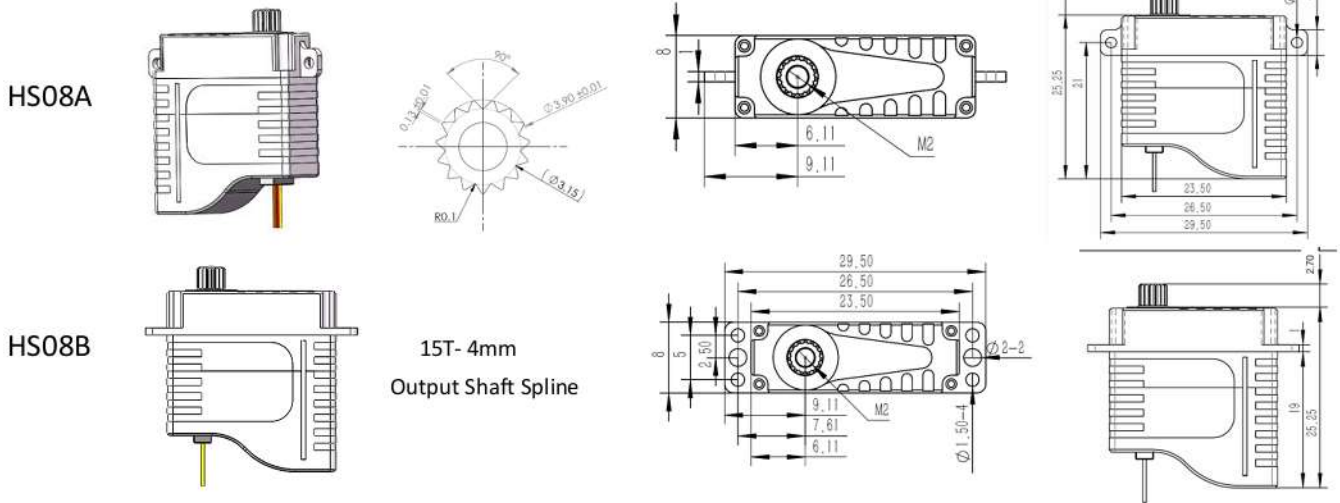

15T- 4mm
Output Shaft Spline

1. Operating Data

Rated Voltage	DC6.0V
Voltage Range	DC3.8V-8.4V
Stalling Torque	2.8Kgf.cm@3.8V
	4.5Kgf.cm@6.0V
	5.2Kgf.cm@7.4V
Speed	0.21sec/60°@3.8V
	0.13sec/60°@6.0V
	0.11sec/60°@7.4V
Start Current	0.68A@6.0V
Rated Torque	1.5kgf.cm@6.0V
Rated Current	0.25A@6.0V
Rated Speed	0.20sec/60°@6.0V
Working Frequency	1520us/333Hz
Default Travel Angle	±60° =120° Total
Temperature Range	-10°C.....+65°C
Soft Start	Programmable
Programmable	Yes
Case Material	Aluminum Alloy
Motor Type	Coreless DC Motor
Gear Set Material	Metal Gear
Position Sensor	Potentiometer
Ball Bearing	2BB
Case Dimensions	23.5*8*25.25±0.2mm
Weight	11g±10%

2. Performance

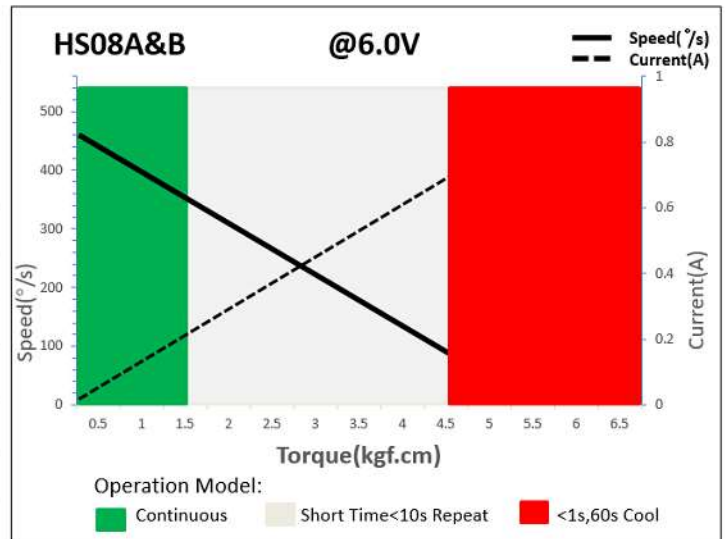

3. Command signal PWM Command Interface

Signal Voltage	HIGH: min.3.3V, max.5.0V Low: min.0.0V, max.1.5V
Pulse Lengths	900us-2100us
Pulse Lengths for Position	1000us/1500us/2000us
	-60°/ 0°/+60°

4. Electrical Connection

Pin Assignment				
	1	Orange	Signal	PWM Command
	2	Red	DC+	Supply Voltage
	3	Brown	DC-	Supply Ground