

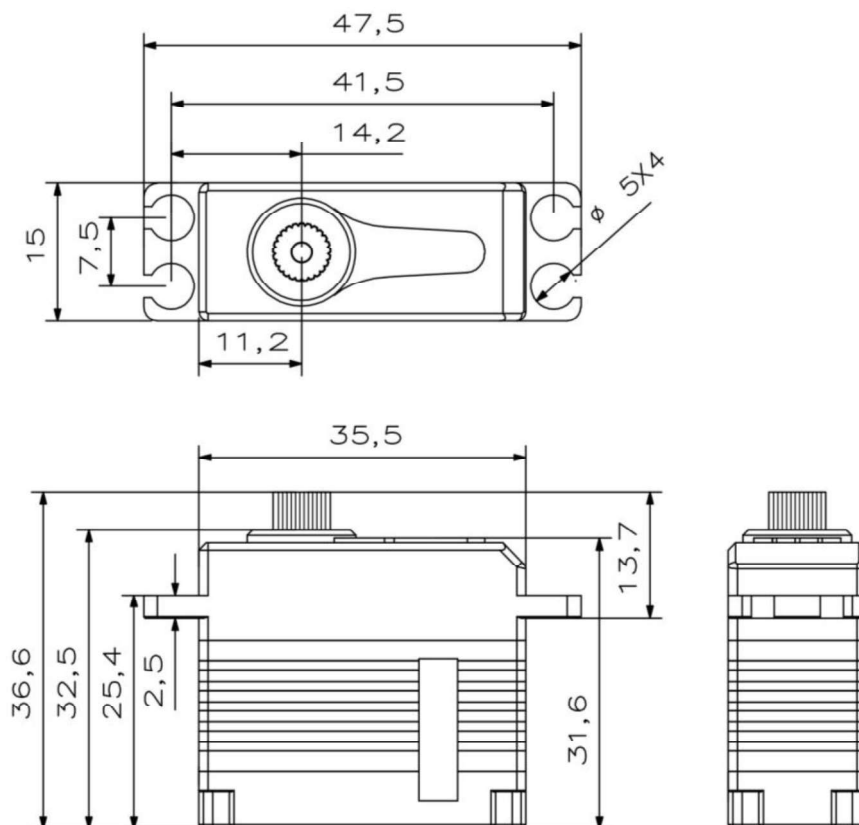

X15-908 V8.0

Technical Specification



KST[®] Operating Data

	X15-908
Operation Voltage(rated)	DC7.4V
Operation Voltage Range	DC6.0V-8.4V
Torque	6.5Kg.cm@6.0V
	8.0Kg.cm@7.4V
	9.2Kg.cm@8.4V
Speed	0.10sec/60°@6.0V
	0.09sec/60°@7.4V
	0.08sec/60°@8.4V
Travel Angle	± 50° when 1000-2000us
Operating Temperature Range	-10°C+65°C

Performance

X15-908

@7.4V

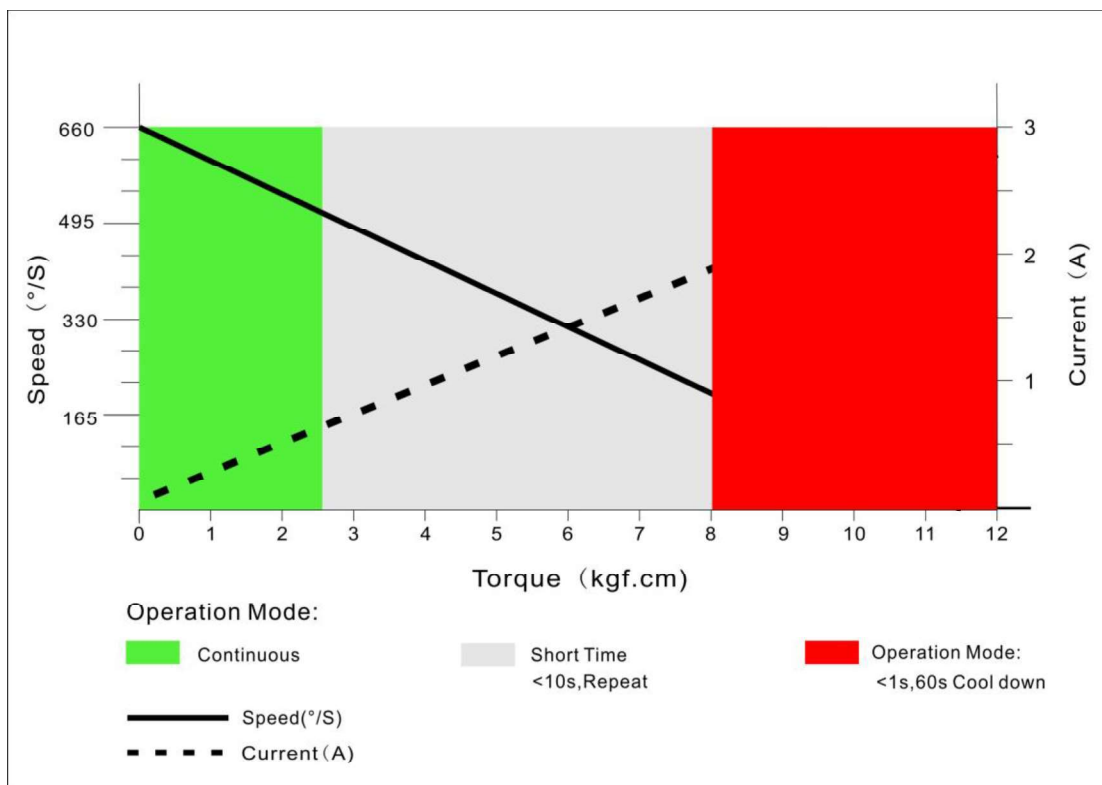

PWM Command Signal

PWM	X15-908
Signal Voltage	TTL-Level: HIGH:min.3.3V,max.5.0V TTL-Level: Low:min.0.0V,max.1.5V
Pulse Lengths	900-2100us
Pulse Lengths for Position -50° /center/ $+50^{\circ}$	1000us/1500us/2000us
Resolution	$\leq 2\mu\text{s}$

Materials and protective features

Case Material	Aluminum Alloy
Motor Type	Coreless
Gear Material	Hardened Steel
Position Sensor	Potentionmeter
Connecting Cable	26AWG

Dimensions

Case Dimensions	35.5*15*32.5mm
Weight	40g