

X30-12-150-* V8.0 HLS Technical Specification

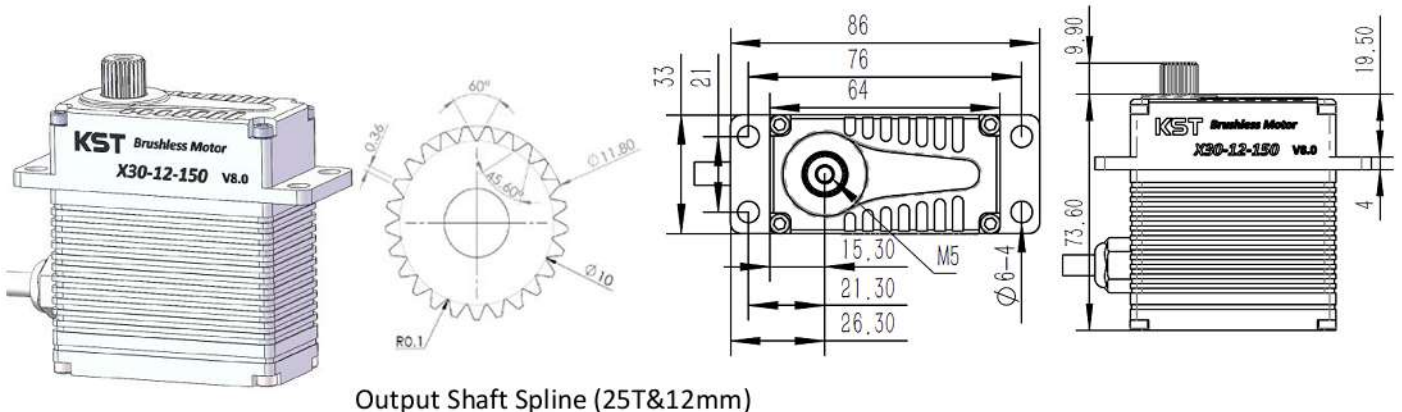

Output Shaft Spline (25T&12mm)

1. Servo Data

X30-12-150-*	
Rated Voltage	DC12V
Voltage Range	DC8.4V-12V
Stalling Torque	10.5N.m@8.4V
	15.0N.m@12V
Speed	0.25sec/60°@8.4V
	0.17sec/60°@12V
Working Frequency	1520us/333Hz
Default Travel Angle	±50°=100° Total
Temperature Range	-20°C.....+65°C
Case Material	Aluminum Alloy
Motor Type	Brushless DC Motor
Gear Set Material	Hardened Steel
Position Sensor	Potentiometer
Case Dimensions	64mm*33mm*74mm±0.2mm
Weight	360g±10%

2. Performance

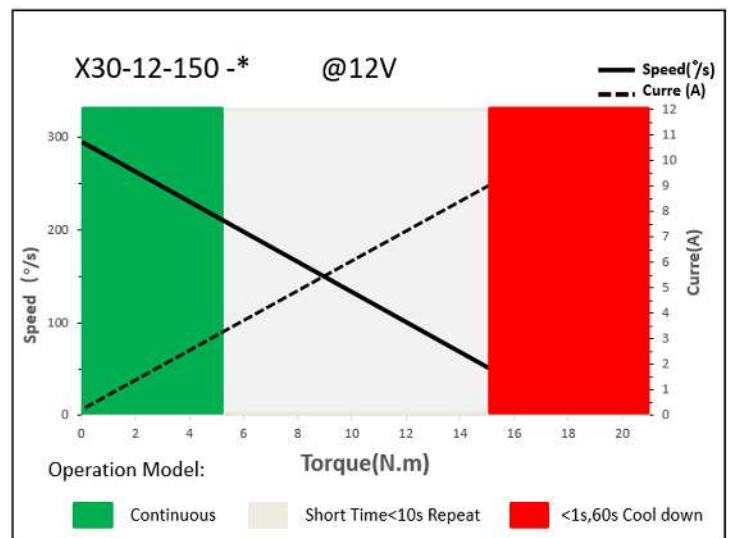

3. Command signal

3.1. PWM Command Interface

Signal Voltage	HIGH: min.3.3V, max.5.0V Low: min.0.0V, max.1.5V
Pulse Lengths	900us-2100us
Pulse Lengths for Position	1000us/1500us/2000us -50°/0°/+50°

3.2. RS485 Command Interface

Baud-Rate	115200 ±1.5% bits/s
Protocol	10 Byte (incl. 1 byte Check Sum)
(Documentation)	8
Number of Data	1
Number of Stop	None

Bits

Command / Response Frame			
Byte #	Description	Byte #	Description
1	Frame Head(0xFE)	6	Data
2	Version(0xCA)	7	Data
3	Address	8	Data
4	Command code	9	Check Sum
5	Data	10	(0A) Frame End

3.3 CAN Bus Command Interface

Baud-Rate	Default value 500Kbps	Communication	CAN Open standard frame CAN Extended frame
Node number	0 x25 (range 1 ~ 127, 0 is radio)		

3.4. Feedback Signal

3.4.1 Position Feedback Signal (PWM Versions)

The Position Feedback signal is an output signal with a square wave which is directly related to the output shaft's angular position. Reference is Supply Ground.

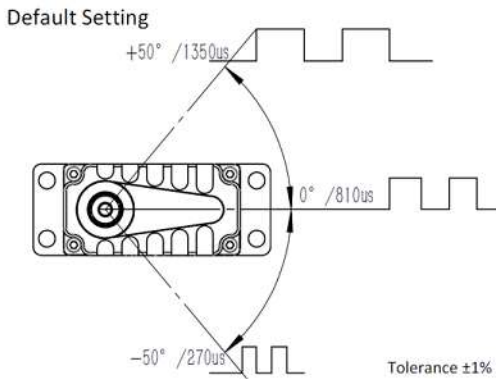

Position Feedback

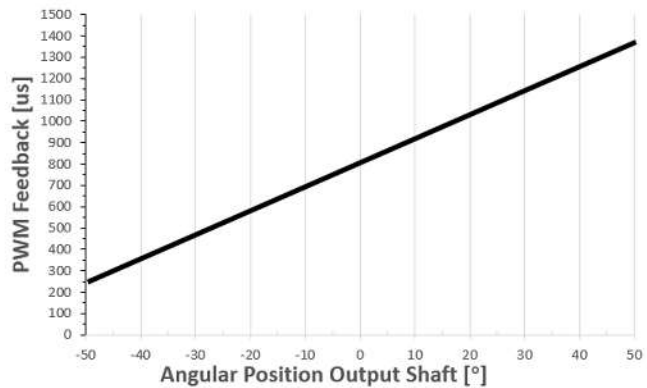

3.4.2 Feedback Value (Bus Version)

Integrated in the Bus protocol a Feedback Value, including the Angle position, Temperature, current value. Value read by sending request command. Provide the details of the bus in the document.

4. Electrical Connection

Pin	Assignment PWM		Assignment RS485 BUS		Assignment CAN BUS	
	Pin	Assignment	Pin	Assignment	Pin	Assignment
1	1	DC+ SupplyVoltage	1	DC+ SupplyVoltage	1	DC+ SupplyVoltage
2	2	DC- Supply Ground	2	DC- Supply Ground	2	DC- Supply Ground
3	3	PWM Signal	3	RS485A	3	CAN-H
4	4	Signal Ground	4	RS485B	4	CAN-L

*: 1-PWM. 2- RS485. 3.1- CANBUS Standard Frame. 3.2- CANBUS Extended Frame